

Projected Beam Smoke Detector



Description

Gamewell's projected beam smoke detector offers vital fire detection in applications where spot-type detectors are not adequate. This model is four-wire, 24 VDC and includes both the transmitter and receiver. Features include automatic compensation for signal drift or dirty lens, alignment LEDs for simple setup and adjustment and three field-adjustable sensitivity settings. This detector provides linear protection from 30 to 320 feet (9.144 to 97.539 m).

Operation

The infrared signal is sent from the transmitter via an optical system. At 320 feet (97.536 m), the diameter of

this infrared signal is approximately 9.5 feet (2.896 m). The wide angle beam arrangement simplifies alignment and increases stability.

It is important that the projected beam smoke detector is positioned correctly to minimize the detection time. Experiments have shown that smoke from a fire does not rise directly upwards. The smoke fans out in a "mushroom" shape due to air currents and heat-layering effects.

A fire alarm condition occurs when the smoke obscures the infrared beam. The time to detect a fire condition depends on the location of the smoke beam within the premises, the volume of smoke produced, the construction of the roof, and ventilation considerations.

System Description

Gamewell's projected beam smoke detector is a transmitter, which projects a modulated infrared light beam on the receiver unit. The received signal is analyzed in the controller. Should smoke be present in the beam for a period of approximately 8 to 10 seconds, a fire relay is activated.

The system is designed to be mounted so that the beam will project between 1 to 2 feet (0.305 to 0.61 m) below and parallel to the roof or ceiling level at ranges up to 320 feet (97.536 m). The maximum lateral detection range is 24.5 feet (7.478 m) on either side of the actual beam.

Smoke Detection

When smoke is present in the beam path, the received signal is reduced by a level determined by the density of the smoke. If the smoke reduces the signal strength for a period between 8 to 10 seconds, the fire alarm relay is activated.

Features

- Microprocessor based.
- Easily aligned.
- Signal strength indicating LEDs.
- 320 feet (97.3536 m) coverage.
- Automatic compensation for "dirty" lens.
- Latching or non-latching alarm contacts.
- Trouble contacts.
- Separate control panel.
- External alarm LED.
- Adjustable sensitivity.
- Internal test switch.
- 24 VDC operation.

Listings

Listings and approvals below apply to the Projected Beam Smoke Detector. In some cases, certain modules may not be listed by certain approval agencies, or listing may be in process. Consult factory for latest listing status.

- UL Listed:

This sensitivity level can be selected to suit different environments. The sensitivity levels available are: 25%, 35%, and 50%.

Auto Reset

After a fault condition is indicated, the control unit automatically resets if the fault is not present.

The fire alarm relay may be latching or non-latching (close alarm switch for latching).

Automatic Gain Control (AGC)

Long-term degradation of signal strength by component aging or buildup of dirt on surfaces, will not generate an alarm because of compensation provided by an AGC circuit. The AGC operates by comparing the received signal against a standard at predetermined time intervals. Differences of more than 7% are corrected by the automatic selection of gain stages.

The AGC interval is factory set to 1.5 hours.

A calibrated test filter is available to test and verify the sensitivity setting of the projected beam smoke detectors. When this compensating capability reaches a limit, the microprocessor automatically generates a trouble signal. The projected beam smoke detectors shall also signal a trouble condition if the beam has a blockage of 90% for more than twenty seconds and automatically resets to normal when the blockage is removed.

The projected beam smoke detector(s) shall be UL-Listed for these applications.

Voltage and RF transient protection is integral to the internal circuitry of the projected beam smoke detector to minimize false alarm potential.

Engineering Specifications

The contractor shall furnish and install, where indicated on the plans, projected beam type smoke detectors. The detector shall have a range of 30 to 320 feet (9.144 to 97.536 m). The projected beam smoke detector shall be field adjustable to one of the obscuration settings of 25%, 50%, or 70% per span.

These settings shall be capable of being verified with calibrated filters.

Side to side spacing shall be a maximum of 45 feet (13.716 m) on center.

The projected beam smoke detector shall possess circuitry that automatically compensates for normal ambient changes in the intensity of the emitted beam strength. The microprocessor shall provide compensation for a change in received signal value, over time, caused by contamination of the optics. Since such a change with time appears as a slow change in the beam signal, the microprocessor compensates in such a manner that the signal moves closer to the reference data at a rate of approximately +1% per hour.

All adjustments shall be made at the low level control unit. Beam detectors that require adjustments at the receiver are not acceptable

The beam smoke detectors shall be Gamewell part number 72051.

Specifications

Control unit

Housing: double pressed sheet.

Steel finish: white enamel.

Weight: 4.95 lbs. (2.245 kg).

Input voltage: 12/24 VDC (nominal).

Standby: 8 mA @ 24 VDC per channel.

Fire alarm threshold: 2 dB (approx.).

Temperature range: -4°F to 131°F. (-20°C to 55°C)

Protection: 100 mA fuse per channel.

Transmitter and receiver

Housing: zinc alloy.

Finish: white enamel.

Weight: 12 oz. (0.34 kg).

Transmitter: 12/24 VDC (nominal).

Receiver: supplied by the control.

Transmitter current: T5 mA @ 24 VDC.

Temperature range: -4°F to 131°F (-20°C to 55°C).

Alignment: external universal bracket.

Wiring Diagram

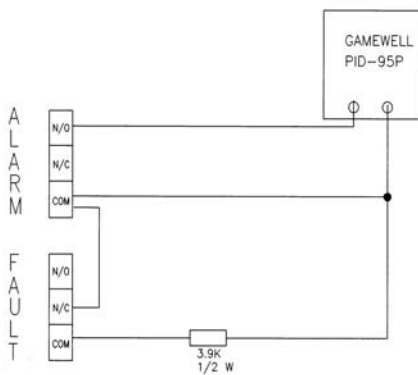
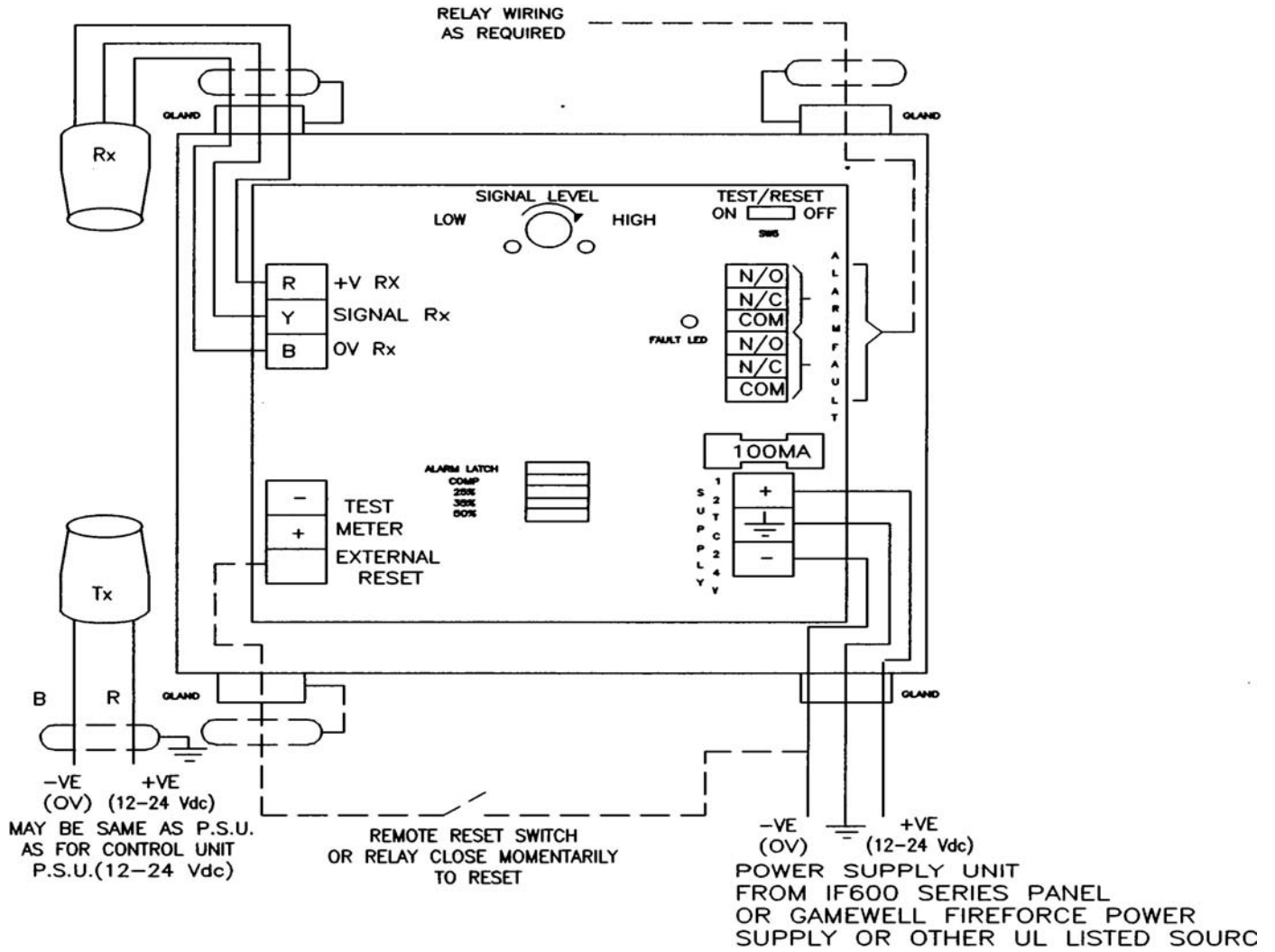

DETAIL OF WIRING FROM CONTROLLER TO GAMEWELL IF600 SERIES CONTROL PANELS

Spacing

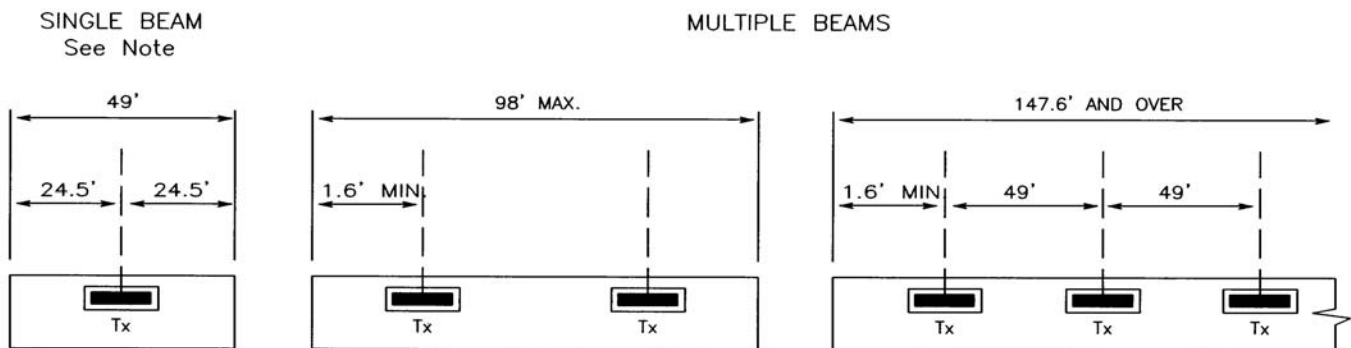

Ordering Information

- 72051** Projected beam smoke detector, 24 VDC, transmitter, receiver, and control unit (FFE2000).
- 72156** Alignment tool, optional (FFE0201-01).



A Honeywell Company

Gamewell-FCI
12 Clintonville Road
Northford, CT 06472-1610
Phone: 203-484-7161
Fax: 203-484-7118
www.gamewell-fci.com

A Honeywell Company
© 2006 Gamewell-FCI

Specifications and wiring information are provided for information only and are believed to be accurate. Gamewell-FCI assumes no responsibility for their use. Data and design are subject to change without notice. Installation and wiring instructions shipped with the product shall always be used for actual installation. For more information, contact Gamewell-FCI.